

Product information presented here reflects conditions at time of publication. Consult factory regarding discrepancies or inconsistencies.



TECHNICAL DATA SHEET

HIGH HEAD FLOW - MATE SERIES

Models 161/4161, 163/4163, 165/4165 Submersible Effluent Pumps

PRODUCT SPECIFICATIONS

MOTOR	Horse Power	1/2 (161/4161, 163/4163) or 1 (165/4165)
	Voltage	115 - 575
	Phase	1 or 3 Ph
	Hertz	60 Hz
	RPM	3450
	Type	Permanent split capacitor or 3 Ph
	Insulation	Class B
	Amps	2.4 - 15.5
PUMP	Operation	Automatic or nonautomatic
	Auto On/Off Points	15-3/4" (400 mm) / 5-1/4" (133 mm)
	Discharge Size	1-1/2" NPT (optional 2" or 3" flange)
	Solids Handling	3/4" (19 mm) spherical solids
	Cord Length	20' (6 m) standard
	Cord Type	1 Ph: UL listed 3-wire neoprene cord and plug or 3 Ph: 4-wire with no plug
	Max. Head	86.5' (26 m)
	Max. Flow Rate	100 GPM (379 LPM)
	Max. Operating Temp.	130 °F (54 °C)
	Cooling	Oil filled
	Motor Protection	Auto reset thermal overload (1 Ph)
MATERIALS	Upper Bearing	Ball bearing
	Lower Bearing	Ball bearing
	Mechanical Seals	Carbon and ceramic
	Impeller Type	Non-clogging, vortex
	Impeller	Bronze
	Hardware	Stainless steel
	Motor Shaft	SAE 1117 carbon steel or 416 stainless steel*
Gasket	Neoprene square ring and gasket	

SINGLE SEAL

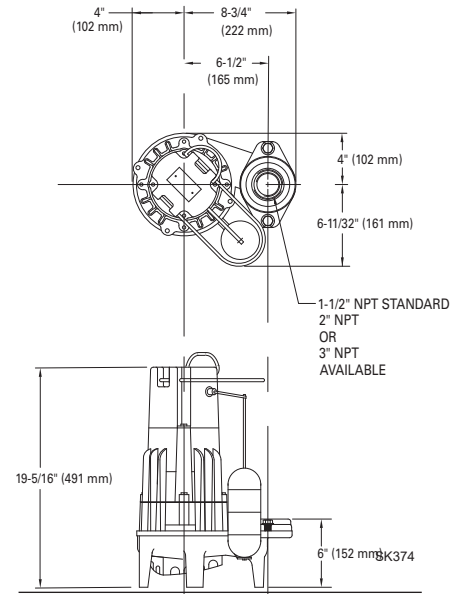

DOUBLE SEAL

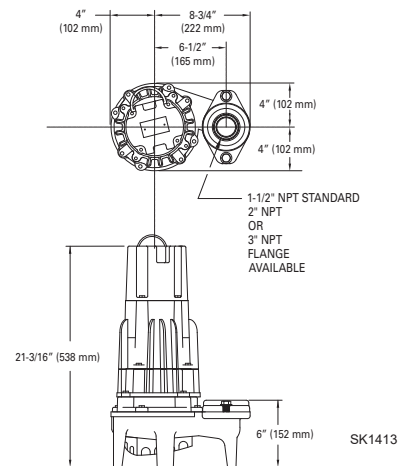

*Single seal models are built with a carbon steel motor shaft, and double seal models are built with a stainless steel motor shaft.

All Class 30 cast iron construction.

NOTE: The sizing of effluent systems normally requires variable level float(s) controls and properly sized basins to achieve required pumping cycles or dosing timers with nonautomatic pumps.

NOTE: See model comparison chart for specific details.



Tested to Standard UL778 and Certified to CSA Standard C22.2 No. 108



TOTAL DYNAMIC HEAD FLOW PER MINUTE

MODELS		161/4161		163/4163		165/4165	
Feet	Meters	Gal.	Liters	Gal.	Liters	Gal.	Liters
5	1.5	100	379	61	231	61	231
10	3.0	93	352	60	227	60.5	229
15	4.6	86	326	60	227	60.3	228
20	6.1	79	299	59	223	60	227
25	7.6	71	267	57	216	59	223
30	9.1	62	235	55	208	58	220
40	12.2	45	170	46	174	55	208
50	15.2	20	76	33	125	50	189
60	18.3	--	--	15	57	39	148
70	21.3	--	--	--	--	22.5	85
80	24.4	--	--	--	--	10	38
Shut-off Head:		56 ft. (17.1 m)		66 ft. (20.1 m)		86.5 ft. (26.4 m)	

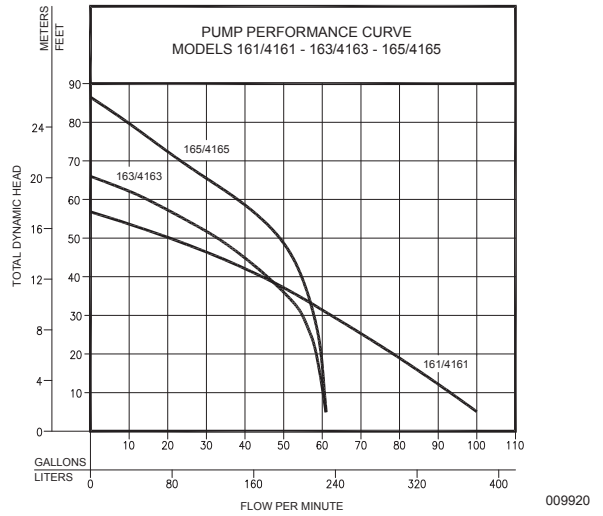

Model	MODEL COMPARISON											CERTIFICATIONS
	Seal	Mode	Volts	Ph	Amps	HP	Hz	Lbs	Kg	Simplex	Duplex	
M161	Single	Auto	115	1	15.0	1/2	60	80	36	1	---	cCSAus ⁽²⁾
N161	Single	Non	115	1	15.0	1/2	60	80	36	2 or 3 & 5	4 & 5	CSA ⁽³⁾
N4161	Double	Non	115	1	15.5	1/2	60	87	39	3 & 5	4 & 5	cCSAus ⁽²⁾
BN161	Single	Auto	115	1	15.0	1/2	60	84	38	---	---	CSA ⁽³⁾
D161	Single	Auto	230	1	7.5	1/2	60	80	36	1	---	cCSAus
E161 / E4161	Single / Double	Non	230	1	7.5	1/2	60	80 / 87	36 / 39	2 or 3 & 5	4 & 5	cCSAus
* H161	Single	Auto	200	1	8.8	1/2	60	80	36	1	---	cCSAus
* I161 / I4161	Single / Double	Non	200	1	8.8	1/2	60	80 / 87	36 / 39	2 or 3 & 5	4 & 5	cCSAus
* J161 / J4161	Single / Double	Non	200	3	6.4	1/2	60	80 / 87	36 / 39	3 & 5	4 & 5	cCSAus
* F161 / F4161	Single / Double	Non	230	3	5.2	1/2	60	80 / 87	36 / 39	3 & 5	4 & 5	cCSAus
* G161 / G4161	Single / Double	Non	460	3	2.9	1/2	60	80 / 87	36 / 39	3 & 5	4 & 5	cCSAus
* BA161/BA4161	Single / Double	Non	575	3	2.4	1/2	60	80 / 87	36 / 39	3 & 5	4 & 5	cCSAus
BE161	Single	Auto	230	1	7.5	1/2	60	84	38	---	---	cCSAus
M163	Single	Auto	115	1	15.0	1/2	60	80	36	1	---	cCSAus ⁽²⁾
N163 / N4163	Single / Double	Non	115	1	15.0	1/2	60	80 / 87	36 / 39	2 or 3 & 5	4 & 5	CSA ⁽³⁾
BN163	Single	Auto	115	1	15.0	1/2	60	84	38	---	---	CSA ⁽³⁾
D163	Single	Auto	230	1	7.5	1/2	60	80	36	1	---	cCSAus
E163 / E4163	Single / Double	Non	230	1	7.5	1/2	60	80 / 87	36 / 39	2 or 3 & 5	4 & 5	cCSAus
* H163	Single	Auto	200	1	8.5	1/2	60	80	36	1	---	cCSAus
* I163 / I4163	Single / Double	Non	200	1	8.5	1/2	60	80 / 87	36 / 39	2 or 3 & 5	4 & 5	cCSAus
* J163 / J4163	Single / Double	Non	200	3	6.0	1/2	60	80 / 87	36 / 39	3 & 5	4 & 5	cCSAus
* F163 / F4163	Single / Double	Non	230	3	4.8	1/2	60	80 / 87	36 / 39	3 & 5	4 & 5	cCSAus
* G163 / G4163	Single / Double	Non	460	3	2.9	1/2	60	80 / 87	36 / 39	3 & 5	4 & 5	cCSAus
* BA163/BA4163	Single / Double	Non	575	3	2.4	1/2	60	80 / 87	36 / 39	3 & 5	4 & 5	cCSAus
BE163	Single	Auto	230	1	7.5	1/2	60	84	38	---	---	cCSAus
D165	Single	Auto	230	1	10.2	1	60	80	36	1	---	cCSAus
E165 / E4165	Single / Double	Non	230	1	10.2	1	60	80 / 87	36 / 39	2 or 3 & 5	4 & 5	cCSAus
* H165	Single	Auto	200	1	12.6	1	60	80	36	1	---	cCSAus
* I165 / I4165	Single / Double	Non	200	1	12.6	1	60	80 / 87	36 / 39	2 or 3 & 5	4 & 5	cCSAus
* J165 / J4165	Single / Double	Non	200	3	7.5	1	60	80 / 87	36 / 39	3 & 5	4 & 5	cCSAus
* F165 / F4165	Single / Double	Non	230	3	7.4	1	60	80 / 87	36 / 39	3 & 5	4 & 5	cCSAus
* G165 / G4165	Single / Double	Non	460	3	3.7	1	60	80 / 87	36 / 39	3 & 5	4 & 5	cCSAus
* BA165/BA4165	Single / Double	Non	575	3	3.0	1	60	80 / 87	36 / 39	3 & 5	4 & 5	cCSAus
BE165	Single	Auto	230	1	10.2	1	60	84	38	---	---	cCSAus

* no molded plug (1) cCSAus approved unit available with 20 Amp plug. (2) 20 Amp duplex receptacle, P/N 10-0060 available.(3) CSA Approved unit with 15 Amp plug.
Additional cords lengths are available in 25' (8 m), 35' (11 m), and 50' (15 m).

SELECTION GUIDE

1. Integral float operated mechanical switch, no external control required.
2. For automatic use single piggyback variable level float switch or double piggyback variable level float switch. Refer to FM0477.
3. See FM1228 for correct model of simplex control panel.
4. See FM0712 for correct model of duplex control panel.
5. Variable level control switch 10-0743 used as a control activator, specify simplex (3) float or duplex (4) float system. Refer to FM0526.

CAUTION

All installation of controls, protection devices and wiring should be done by a qualified licensed electrician. All electrical and safety codes should be followed including the most recent National Electrical Code (NEC) and the Occupational Safety and Health Act (OSHA).

© Copyright 2019 Zoeller® Co. All rights reserved.

502-778-2731 | 800-928-7867 | 3649 Cane Run Road | Louisville, KY 40211-1961 | zoeller.com